

IEC SYSTEM FOR MUTUAL RECOGNITION OF TEST
CERTIFICATES FOR ELECTRICAL EQUIPMENT
(IECEE) CB SCHEME

SYSTEME CEI D'ACCEPTATION MUTUELLE DE
CERTIFICATS D'ESSAIS DES EQUIPEMENTS
ELECTRIQUES (IECEE) METHODE OC

CB TEST CERTIFICATE

CERTIFICAT D'ESSAI OC

Product
Produit

Lithium-ion Polymer Battery

Name and address of the applicant
Nom et adresse du demandeur

Shenzhen Honcell Energy Co., Ltd.
612, Bldg. A, Weidonglong
Industrial Zone, Meilong Ave. 194 #, Longhua New District, Shenzhen
518109, P.R. China

Name and address of the manufacturer
Nom et adresse du fabricant

Shenzhen Honcell Energy Co., Ltd.
612, Bldg. A, Weidonglong
Industrial Zone, Meilong Ave. 194 #, Longhua New District, Shenzhen
518109, P.R. China

Name and address of the factory
Nom et adresse de l'usine

Shenzhen Honcell Energy Co., Ltd.
612, Bldg. A, Weidonglong
Industrial Zone, Meilong Ave. 194 #, Longhua New District, Shenzhen
518109, P.R. China

Ratings and principal characteristics
Valeurs nominales et caractéristiques principales

3.7V, 250mAh, 0.93Wh

Trademark (if any)
Marque de fabrique (si elle existe)

HONCELL

Type of Manufacturer's Testing Laboratories used
Type de programme du laboratoire d'essais constructeur

N/A

Model / Type Ref.
Ref. de type

HCP502030W

Additional information (if necessary may also be
reported on page 2)
Les informations complémentaires (si nécessaire,
peuvent être indiqués sur la 2^{ème} page)

A sample of the product was tested and found
to be in conformity with
Un échantillon de ce produit a été essayé et a été
considéré conforme à la

IEC 62133:2012
See Test Report for National Differences

As shown in the Test Report Ref. No. which forms part
of this Certificate
Comme indiqué dans le Rapport d'essais numéro de
référence qui constitue partie de ce Certificat

50070719 001

This CB Test Certificate is issued by the National Certification Body
Ce Certificat d'essai OC est établi par l'Organisme National de Certification



TÜV Rheinland Japan Ltd.
Global Technology Assessment Center
4-25-2 Kita-Yamata, Tsuzuki-ku
Yokohama 224-0021 Japan
Phone + 81 45 914-3888
Fax + 81 45 914-3354
Mail: info@jpn.tuv.com
Web: www.tuv.com

Date: 03.03.2017

Signature:

Dipl.-Ing. (FH) C. Padel



Test Report issued under the responsibility of:



**TEST REPORT
IEC 62133**

Secondary cells and batteries containing alkaline or other non-acid electrolytes – Safety requirements for portable sealed secondary cells, and for batteries made from them, for use in portable applications

Report Number.: 50070719 001

Date of issue: 2017-03-03

Total number of pages 28 pages

Applicant's name.....: Shenzhen Honcell Energy Co., Ltd.

Address: 612, Bldg. A, Weidonglong Industrial Zone, Meilong Ave. 194 #, Longhua New District, Shenzhen 518109, P.R.China.

Test specification:

Standard: IEC 62133: 2012 (Second Edition)

Test procedure: CB Scheme

Non-standard test method.....: N/A

Test Report Form No.....: IEC62133B

Test Report Form(s) Originator: UL(Demko)

Master TRF.....: Dated 2013-03

Copyright © 2013 Worldwide System for Conformity Testing and Certification of Electrotechnical Equipment and Components (IECEE), Geneva, Switzerland. All rights reserved.

This publication may be reproduced in whole or in part for non-commercial purposes as long as the IECEE is acknowledged as copyright owner and source of the material. IECEE takes no responsibility for and will not assume liability for damages resulting from the reader's interpretation of the reproduced material due to its placement and context.

If this Test Report Form is used by non-IECEE members, the IECEE/IEC logo and the reference to the CB Scheme procedure shall be removed.

This report is not valid as a CB Test Report unless signed by an approved CB Testing Laboratory and appended to a CB Test Certificate issued by an NCB in accordance with IECEE 02.

Test item description: Lithium-ion Polymer Battery

Trade Mark: 

Manufacturer.....: Same as applicant

Address: Same as applicant

Model/Type reference: HCP502030W

Ratings: 3.7V, 250mAh, 0.93Wh

Testing procedure and testing location:		
<input checked="" type="checkbox"/>	CB Testing Laboratory:	TÜV Rheinland (Shenzhen) Co., Ltd.
Testing location/ address		East of F/1, F/2~F/4, Building 1, Cybio Technology Building No. 6 Langshan No.2 Road, North Hi-tech Industry Park 518057 Shenzhen Nanshan District CHINA
<input type="checkbox"/>	Associated CB Testing Laboratory:	
Testing location/ address		
Tested by (name + signature).....:		Eric Cui <i>Eric Cui</i>
Approved by (name + signature)		Daniel Dai <i>Daniel Dai</i>
<input type="checkbox"/>	Testing procedure: TMP	
Testing location/ address		
Tested by (name + signature).....:		
Approved by (name + signature)		
<input type="checkbox"/>	Testing procedure: WMT	
Testing location/ address		
Tested by (name + signature).....:		
Witnessed by (name + signature)		
Approved by (name + signature)		
<input type="checkbox"/>	Testing procedure: SMT	
Testing location/ address		
Tested by (name + signature).....:		
Approved by (name + signature)		
Supervised by (name + signature)....:		

List of Attachments (including a total number of pages in each attachment): - Attachment 1: Photo documentation (3 pages)	
Summary of testing:	
Tests performed (name of test and test clause): cl.5.6.2 Design recommendation(Lithium system); cl.8.1 Charging procedure for test purposes (for Cells and Batteries); cl.8.2.1 Continuous charging at constant voltage (Cells); cl.8.3.1 External short circuit (Cells); cl.8.3.2 External short circuit (Batteries); cl.8.3.3 Free fall (Cells and Batteries); cl.8.3.4 Thermal abuse (Cells); cl.8.3.5 Crush (Cells); cl.8.3.6 Over-charging of battery; cl.8.3.7 Forced discharge (Cells); cl.8.3.8 Transport tests (Cells); cl.8.3.9 Design evaluation – Forced internal short circuit (Cells). Tests are made with the number of cells and batteries specified in IEC 62133: 2012 (Second Edition) Table 2.	Testing location: TÜV Rheinland (Shenzhen) Co., Ltd. East of F/1, F/2–F/4, Building 1, Cybio Technology Building No. 6 Langshan No.2 Road, North Hi-tech Industry Park 518057 Shenzhen Nanshan District CHINA
Summary of compliance with National Differences: BE, BY, CN, DE, DK, FI, FR, GB, HU, JP, KR, NL, NO, SA, SE, SG, SI, US BE=Belgium, BY= Belarus, CN=China, DE=Germany, DK=Denmark, FI=Finland, FR=France, GB=United Kingdom, HU=Hungary, JP=Japan, KR=Republic of Korea, NL=Netherlands, NO=Norway, SA=Saudi Arabia, SE=Sweden, SG=Singapore, SI=Slovenia, US=United States of America	
<input checked="" type="checkbox"/> The product fulfils the requirements of <u>EN 62133: 2013</u>	

Copy of marking plate:

The artwork below may be only a draft. The use of certification marks on a product must be authorized by the respective NCBS that own these marks.

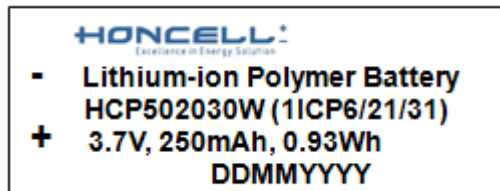

Remark: DDMMYYYY represents the date of manufacture.

Test item particulars:	
Classification of installation and use:	To be defined in final product
Supply connection:	Electronic Wire
Recommend charging method declared by the manufacturer	Charging the battery with 50mA constant current until 4.20V, then constant voltage until charge current reduces to 2.5mA at ambient 20°C±5°C
Discharge current (0,2 I_L A)	50mA
Specified final voltage	3.0V
Chemistry	<input type="checkbox"/> nickel systems <input checked="" type="checkbox"/> lithium systems
Recommend of charging limit for lithium system	
Upper limit charging voltage per cell:	4.25V
Maximum charging current	250mA
Charging temperature upper limit	45°C
Charging temperature lower limit:	0°C
Polymer cell electrolyte type	<input type="checkbox"/> gel polymer <input type="checkbox"/> solid polymer <input checked="" type="checkbox"/> N/A
Possible test case verdicts:	
- test case does not apply to the test object.....:	N/A
- test object does meet the requirement.....:	P (Pass)
- test object does not meet the requirement.....:	F (Fail)
Testing:	
Date of receipt of test item	2017-01-16
Date (s) of performance of tests	2017-01-16 to 2017-02-18
General remarks:	
The test results presented in this report relate only to the object tested. This report shall not be reproduced, except in full, without the written approval of the Issuing testing laboratory. "(See Enclosure #)" refers to additional information appended to the report. "(See appended table)" refers to a table appended to the report. Throughout this report a <input type="checkbox"/> comma / <input checked="" type="checkbox"/> point is used as the decimal separator.	
Manufacturer's Declaration per sub-clause 4.2.5 of IEC 60335-1:	
The application for obtaining a CB Test Certificate includes more than one factory location and a declaration from the Manufacturer stating that the sample(s) submitted for evaluation is (are) representative of the products from each factory has been provided :	<input type="checkbox"/> Yes <input checked="" type="checkbox"/> Not applicable
When differences exist; they shall be identified in the General product information section.	
Name and address of factory (ies)	Same as applicant

General product information:

The battery is constructed with one Lithium-ion cell (1S1P), and has overcharge, over-discharge, over current and short-circuits proof circuit.

The main features of the battery are shown as below (clause 8.1.1):

Model	Nominal capacity	Nominal voltage	Nominal Charge Current	Nominal Discharge Current	Maximum Charge Current	Maximum Discharge Current	Maximum Charge Voltage	Cut-off Voltage
HCP502030W	250mAh	3.7V	50mA	50mA	250mA	250mA	4.20V	3.0V

The main features of the battery are shown as below (clause 8.1.2):

Model	Upper limit charge voltage	Taper-off current	Lower charge temperature	Upper charge temperature
HCP502030W	4.25V	12.5mA	0°C	45°C

The main features of the cell in the battery are shown as below (clause 8.1.1):

Model	Nominal capacity	Nominal voltage	Nominal Charge Current	Nominal Discharge Current	Maximum Charge Current	Maximum Discharge Current	Maximum Charge Voltage	Cut-off Voltage
HCP502030	250mAh	3.7V	50mA	50mA	250mA	250mA	4.20V	3.0V

The main features of the cell in the battery are shown as below (clause 8.1.2):

Model	Upper limit charge voltage	Taper-off current	Lower charge temperature	Upper charge temperature
HCP502030	4.25V	12.5mA	0°C	45°C

Construction:

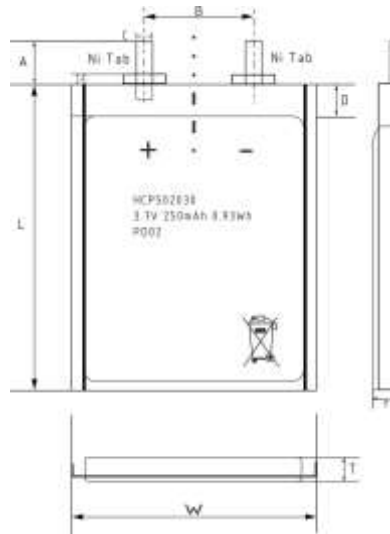

- Thickness (T)	Max. 5.0 (delivery status)
	Max. 5.3 (after cycling)
- Width (w)	Max. 20.5
- Length (L)	Max. 30.5 (without tabs)
- Tab Distance (B)	9.0±2.0
- Tab Length (A)	4.0±1.0
- Tab Width (C)	2.0±0.2
- Top Sealing Width (D)	3.0
- Tab Sealant Height (E)	1.5mm for Ref.
- Weight Approx. [g]	5.5g

Cell (Unit: mm)



Battery (Unit: mm)

Circuit diagram:

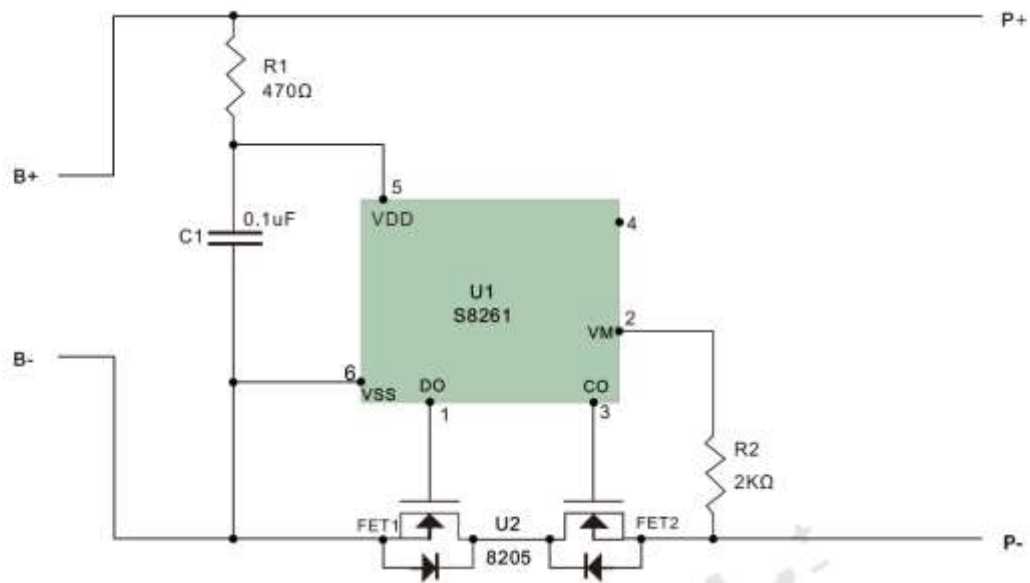

IEC 62133: 2012			
Clause	Requirement + Test	Result - Remark	Verdict
4	Parameter measurement tolerances		P
	Parameter measurement tolerances		P
5	General safety considerations		P
5.1	General		P
5.2	Insulation and wiring		P
	The insulation resistance between the positive terminal and externally exposed metal surfaces of the battery (excluding electrical contact surfaces) is not less than 5 MΩ	No metal case exists.	N/A
	Insulation resistance (MΩ) :		—
	Internal wiring and insulation are sufficient to withstand maximum anticipated current, voltage and temperature requirements		P
	Orientation of wiring maintains adequate creepage and clearance distances between conductors		P
	Mechanical integrity of internal connections accommodates reasonably foreseeable misuse		P
5.3	Venting		P
	Battery cases and cells incorporate a pressure relief mechanism or are constructed so that they relieve excessive internal pressure at a value and rate that will preclude rupture, explosion and self-ignition	Venting mechanism exists on the narrow side of pouch cell.	P
	Encapsulation used to support cells within an outer casing does not cause the battery to overheat during normal operation nor inhibit pressure relief		N/A
5.4	Temperature/voltage/current management		P
	Batteries are designed such that abnormal temperature rise conditions are prevented	Overcharge, overdischarge, over current and short-circuit proof circuit used in this battery. See tests of clause 8.	P
	Batteries are designed to be within temperature, voltage and current limits specified by the cell manufacturer	See above.	P
	Batteries are provided with specifications and charging instructions for equipment manufacturers so that associated chargers are designed to maintain charging within the temperature, voltage and current limits specified	The charging limits are specified in the manufacturer's specifications.	P
5.5	Terminal contacts		P
	Terminals have a clear polarity marking on the external surface of the battery	See Page 4.	P

IEC 62133: 2012			
Clause	Requirement + Test	Result - Remark	Verdict
	The size and shape of the terminal contacts ensure that they can carry the maximum anticipated current		P
	External terminal contact surfaces are formed from conductive materials with good mechanical strength and corrosion resistance		P
	Terminal contacts are arranged to minimize the risk of short circuits		P
5.6	Assembly of cells into batteries		P
5.6.1	If there is more than one battery housed in a single battery case, cells used in the assembly of each battery have closely matched capacities, be of the same design, be of the same chemistry and be from the same manufacturer	Single cell battery	N/A
	Each battery has an independent control and protection		N/A
	Manufacturers of cells make recommendations about current, voltage and temperature limits so that the battery manufacturer/designer may ensure proper design and assembly		N/A
	Batteries that are designed for the selective discharge of a portion of their series connected cells incorporate separate circuitry to prevent the cell reversal caused by uneven discharges		N/A
	Protective circuit components are added as appropriate and consideration given to the end-device application		N/A
	When testing a battery, the manufacturer of the battery provides a test report confirming the compliance according to this standard		N/A
5.6.2	Design recommendation for lithium systems only		P
	For the battery consisting of a single cell or a single cellblock: - Charging voltage of the cell does not exceed the upper limit of the charging voltage specified in Clause 8.1.2, Table 4; or	Charging voltage: 4.2V, not exceed 4.25V specified in Clause 8.1.2, Table 4.	P
	- Charging voltage of the cell does not exceed the different upper limit of the charging voltage determined through Clause 8.1.2, NOTE 1.		N/A
	For the battery consisting of series-connected plural single cells or series-connected plural cellblocks: - The voltages of any one of the single cells or single cellblocks does not exceed the upper limit of the charging voltage, specified in Clause 8.1.2, Table 4, by monitoring the voltage of every single cell or the single cellblocks; or		N/A

IEC 62133: 2012			
Clause	Requirement + Test	Result - Remark	Verdict
	- The voltages of any one of the single cells or single cellblocks does not exceed the different upper limit of the charging voltage, determined through Clause 8.1.2, NOTE 1, by monitoring the voltage of every single cell or the single cellblocks		N/A
	For the battery consisting of series-connected plural single cells or series-connected plural cellblocks: - Charging is stopped when the upper limit of the charging voltage, specified in Clause 8.1.2, Table 4, is exceeded for any one of the single cells or single cellblocks by measuring the voltage of every single cell or the single cellblocks; or		N/A
	- Charging is stopped when the upper limit of the different charging voltage, determined through Clause 8.1.2, NOTE 1, is exceeded for any one of the single cells or single cellblocks by measuring the voltage of every single cell or the single cellblocks		N/A
5.7	Quality plan		P
	The manufacturer prepares and implements a quality plan that defines procedures for the inspection of materials, components, cells and batteries and which covers the whole process of producing each type of cell or battery	Complied. Quality plan provided.	P
6	Type test conditions		P
	Tests were made with the number of cells or batteries specified in Table 1 for nickel-cadmium and nickel-metal hydride systems and Table 2 for lithium systems, using cells or batteries that are not more than six months old	Complied. Table 2 for Lithium system.	P
	Unless noted otherwise in the test methods, testing was conducted in an ambient of 20°C ± 5°C.	Tests are carried out at 20°C ± 5°C.	P
7	Specific requirements and tests (nickel systems)		N/A
7.1	Charging procedure for test purposes	Lithium system.	N/A
7.2	Intended use		N/A
7.2.1	Continuous low-rate charging (cells)		N/A
	Results: No fire. No explosion		N/A
7.2.2	Vibration		N/A
	Results: No fire. No explosion. No leakage	(See Table 7.2.2)	N/A
7.2.3	Moulded case stress at high ambient temperature		N/A
	Oven temperature (°C)		—

IEC 62133: 2012			
Clause	Requirement + Test	Result - Remark	Verdict
	Results: No physical distortion of the battery casing resulting in exposure if internal components		N/A
7.2.4	Temperature cycling		N/A
	Results: No fire. No explosion. No leakage.		N/A
7.3	Reasonably foreseeable misuse		N/A
7.3.1	Incorrect installation cell		N/A
	The test was carried out using: - Four fully charged cells of the same brand, type, size and age connected in series, with one of them reversed; or		N/A
	- A stabilized dc power supply.		N/A
	Results: No fire. No explosion..... :	(See Table 7.3.1)	N/A
7.3.2	External short circuit		N/A
	The cells or batteries were tested until one of the following occurred: - 24 hours elapsed; or		N/A
	- The case temperature declined by 20% of the maximum temperature rise		N/A
	Results: No fire. No explosion..... :	(See Table 7.3.2)	N/A
7.3.3	Free fall		N/A
	Results: No fire. No explosion.		N/A
7.3.4	Mechanical shock (crash hazard)		N/A
	Results: No fire. No explosion. No leakage.		N/A
7.3.5	Thermal abuse		N/A
	Oven temperature (°C)..... :		—
	Results: No fire. No explosion.		N/A
7.3.6	Crushing of cells		N/A
	The crushing force was released upon: - The maximum force of 13 kN ± 1 kN has been applied; or		N/A
	- An abrupt voltage drop of one-third of the original voltage has been obtained		N/A
	The cell is prismatic type and a second set of samples was tested, rotated 90° around longitudinal axis compared to the first set		N/A
	Results: No fire. No explosion..... :	(See Table 7.3.6)	N/A
7.3.7	Low pressure		N/A
	Chamber pressure (kPa)..... :		—

IEC 62133: 2012			
Clause	Requirement + Test	Result - Remark	Verdict
	Results: No fire. No explosion. No leakage.		N/A
7.3.8	Overcharge		N/A
	Results: No fire. No explosion..... :	(See Table 7.3.8)	N/A
7.3.9	Forced discharge		N/A
	Results: No fire. No explosion..... :	(See Table 7.3.9)	N/A
8	Specific requirements and tests (lithium systems)		P
8.1	Charging procedures for test purposes		P
8.1.1	First procedure: This charging procedure applied to tests other than those specified in 8.1.2		P
8.1.2	Second procedure: This charging procedure applied to the tests of 8.3.1, 8.3.2, 8.3.4, 8.3.5		P
	If a cell's specified upper and/or lower charging temperature exceeds values for the upper and/or lower limit test temperatures of Table 4, the cells were charged at the specified values plus 5 °C for the upper limit and minus 5 °C for the lower limit	Charge temperature 0-45°C declared. 45°C used for upper limit test temperature; -5°C used for lower limit test temperature.	P
	A valid rationale was provided to ensure the safety of the cell (see Figure A.1)		P
	For a different upper limit charging voltage (i.e. other than for lithium cobalt oxide systems at 4,25 V), the applied upper limit charging voltage and upper limit charging temperatures were adjusted accordingly	The upper limit charging voltage: 4.25V.	N/A
	A valid rationale was provided to ensure the safety of the cell (see Figure A.1)		N/A
8.2	Intended use		P
8.2.1	Continuous charging at constant voltage (cells)	Tested complied.	P
	Results: No fire. No explosion..... :	(See Table 8.2.1)	P
8.2.2	Moulded case stress at high ambient temperature (battery)	No moulded case exists.	N/A
	Oven temperature (°C)		—
	Results: No physical distortion of the battery casing resulting in exposure if internal components		N/A
8.3	Reasonably foreseeable misuse		P
8.3.1	External short circuit (cell)		P

IEC 62133: 2012			
Clause	Requirement + Test	Result - Remark	Verdict
	The cells were tested until one of the following occurred: - 24 hours elapsed; or		N/A
	- The case temperature declined by 20% of the maximum temperature rise		P
	Results: No fire. No explosion..... :	(See Table 8.3.1)	P
8.3.2	External short circuit (battery)		P
	The cells were tested until one of the following occurred: - 24 hours elapsed; or		P
	- The case temperature declined by 20% of the maximum temperature rise		N/A
	In case of rapid decline in short circuit current, the battery pack remained on test for an additional one hour after the current reached a low end steady state condition		N/A
	Results: No fire. No explosion..... :	(See Table 8.3.2)	P
8.3.3	Free fall		P
	Results: No fire. No explosion.	No fire. No explosion.	P
8.3.4	Thermal abuse (cells)		P
	The cells were held at 130°C ± 2°C for: - 10 minutes; or	Tested complied.	P
	- 30 minutes for large cells (gross mass of more than 500 g as defined in IEC 62281)		N/A
	Oven temperature (°C)..... :	130°C	—
	Gross mass of cell (g)..... :	<500g, Small cell.	—
	Results: No fire. No explosion.	No fire. No explosion.	P
8.3.5	Crush (cells)		P
	The crushing force was released upon: - The maximum force of 13 kN ± 1 kN has been applied; or	Tested complied.	P
	- An abrupt voltage drop of one-third of the original voltage has been obtained; or		N/A
	- 10% of deformation has occurred compared to the initial dimension		N/A
	Results: No fire. No explosion..... :	(See Table 8.3.5)	P
8.3.6	Over-charging of battery		P

IEC 62133: 2012			
Clause	Requirement + Test	Result - Remark	Verdict
	Test was continued until the temperature of the outer casing: - Reached steady state conditions (less than 10°C change in 30-minute period); or		P
	- Returned to ambient		N/A
	Results: No fire. No explosion..... :	(See Table 8.3.6)	P
8.3.7	Forced discharge (cells)		P
	Results: No fire. No explosion..... :	(See Table 8.3.7)	P
8.3.8	Transport tests		P
	Manufacturer's documentation provided to show compliance with UN Recommendations on Transport of Dangerous Goods	Tested complied.	P
8.3.9	Design evaluation – Forced internal short circuit (cells)	Tested complied.	P
	The cells complied with national requirement for :	France, Japan, Republic of Korea, Switzerland.	—
	The pressing was stopped upon: - A voltage drop of 50 mV has been detected; or		P
	- The pressing force of 800 N (cylindrical cells) or 400 N (prismatic cells) has been reached	400N for prismatic cells.	P
	Results: No fire :	(See Table 8.3.9)	P
9	Information for safety		P
	The manufacturer of secondary cells ensures that information is provided about current, voltage and temperature limits of their products.	Information for safety mentioned in manufacturer's specifications.	P
	The manufacturer of batteries ensures that equipment manufacturers and, in the case of direct sales, end-users are provided with information to minimize and mitigate hazards.	Information for safety mentioned in manufacturer's specifications.	P
	Systems analyses performed by device manufacturers to ensure that a particular battery design prevents hazards from occurring during use of a product		N/A
	As appropriate, information relating to hazard avoidance resulting from a system analysis is provided to the end user :		N/A
10	Marking		P
10.1	Cell marking		N/A
	Cells marked as specified in the applicable cell standards: IEC 61951-1, IEC 61951-2 or IEC 61960.	The final product is battery.	N/A

IEC 62133: 2012			
Clause	Requirement + Test	Result - Remark	Verdict
10.2	Battery marking		P
	Batteries marked in accordance with the requirements for the cells from which they are assembled.	The battery is marked in accordance with IEC 61960, also see 4.	P
	Batteries marked with an appropriate caution statement.		N/A
10.3	Other information		P
	Storage and disposal instructions marked on or supplied with the battery.	Information for disposal instructions mentioned in manufacturer's specifications.	P
	Recommended charging instructions marked on or supplied with the battery.	Information for recommended charging instructions mentioned in manufacturer's specifications.	P

11	Packaging		P
	The materials and packaging design are chosen so as to prevent the development of unintentional electrical conduction, corrosion of the terminals and ingress of environmental contaminants.	Information for safety mentioned in manufacturer's specifications.	P

Annex A	Charging range of secondary lithium ion cells for safe use		P
A.1	General		P
A.2	Safety of lithium-ion secondary battery	Complied.	P
A.3	Consideration on charging voltage	Complied.	P
A.3.1	General		P
A.3.2	Upper limit charging voltage	4.25V	P
A.3.2.1	General		P
A.3.2.2	Explanation of safety viewpoint		N/A
A.3.2.3	Safety requirements, when different upper limit charging voltage is applied	4.25V applied.	N/A
A.4	Consideration of temperature and charging current		P
A.4.1	General		P
A.4.2	Recommended temperature range	See A.4.2.2.	P
A.4.2.1	General		P
A.4.2.2	Safety consideration when a different recommended temperature range is applied	Charging temperature declared by client is: 0-45°C	P
A.4.3	High temperature range	Not higher than the temperature range specific in this standard.	N/A

IEC 62133: 2012			
Clause	Requirement + Test	Result - Remark	Verdict
A.4.3.1	General		N/A
A.4.3.2	Explanation of safety viewpoint		N/A
A.4.3.3	Safety considerations when specifying charging conditions in high temperature range		N/A
A.4.3.4	Safety consideration when specifying new upper limit in high temperature range		N/A
A.4.4	Low temperature range	Charging low temperature declared by client is: 0°C.	P
A.4.4.1	General		P
A.4.4.2	Explanation of safety viewpoint		P
A.4.4.3	Safety considerations, when specifying charging conditions in low temperature range		P
A.4.4.4	Safety considerations when specifying a new lower limit in the low temperature range	-5°C applied.	P
A.4.5	Scope of the application of charging current		P
A.5	Sample preparation		P
A.5.1	General		P
A.5.2	Insertion procedure for nickel particle to generate internal short		P
	The insertion procedure carried out at 20°C±5°C and under -25 °C of dew point		P
A.5.3	Disassembly of charged cell		P
A.5.4	Shape of nickel particle		P
A.5.5	Insertion of nickel particle to cylindrical cell		N/A
A.5.5.1	Insertion of nickel particle to winding core		N/A
A.5.5.2	Mark the position of nickel particle on the both end of winding core of the separator		N/A
A.5.6	Insertion of nickel particle to prismatic cell		P

TABLE: Critical components information					P
Object/part no.	Manufacturer/trademark	Type/model	Technical data	Standard	Mark(s) of conformity ¹⁾
Lead wire (Red & Black)	Shenzhen GWX	UL1571	AWG#30, VM-1, 80°C, 30Vac	--	--
PCB	DLX	DLX9437	V-0, 130°C	--	--
Protect IC (U1)	SEIKO	8261 G3J-M6T1U	Overcharge detection voltage: 4.28±0.035V, Overdischarge detection voltage: 3.0±0.08 V, Overcurrent detection voltage: 0.08 V, Short protection voltage: 0.7V-1.7V, T _{opr.} : -40~85°C	--	Tested with appliance
MOSFET (U2)	MT	8205A	V _{DS} : 20V, V _{GS} : ±12V, I _D : 6A, T _J : -55-150°C	--	Tested with appliance
Cell	Shenzhen Honcell Energy Co., Ltd.	HCP502030	3.7Vd.c., 250mAh	IEC 62133: 2012	Tested with appliance
-Electrolyte	Shantou Jinguang High-Tech Co., Ltd.	A1938	LiPF ₆ , EC, EMC, DMC	--	--
-Separator	Shenzhen Xuran Electronics Co., Ltd.	ND16	PE, 16µm(T)×17.5mm(W)×400mm(L), Shutdown temperature: 130°C	--	--
-Negative electrode	Jiangxi Zhengtuo New Energy Technology Co., Ltd.	0.140mm(T)×16mm(W)×173mm(L)	Graphite, CMC, SBR, H ₂ O, Conductive Additive, Copper Foil	--	--
-Positive electrode	Hunan Mt New Materials Technologies Co., Ltd.	0.120mm(T)×15.5mm(W)×182mm(L)	LiCoO ₂ , Super-P, PVDF, NMP, Conductive Additive, Aluminum Foil	--	--
-Positive electrode tab	DongGuan KaiXiang	0.1mm(T)×2mm(W)	Aluminum strip	--	--
-Negative electrode tab	DongGuan KaiXiang	0.1mm(T)×2mm(W)	Nickel strip	--	--
-Aluminum plastic film	DNP	D-EL40H	0.113mm(T)×20mm(W)×46mm(L)	--	--
Supplementary information:					
¹⁾ Provided evidence ensures the agreed level of compliance.					

7.2.1	TABLE: Continuous low rate charge (cells)					N/A
Model	Recommended charging method, (CC, CV, or CC/CV)	Recommended charging voltage V_c , (Vdc)	Recommended charging current I_{rec} , (A)	OCV at start of test, (Vdc)	Results	
Supplementary information: <ul style="list-style-type: none"> - No fire or explosion - No leakage - Leakage - Fire - Explosion - Bulge - Others (please explain) 						

7.2.2	TABLE: Vibration		N/A
Model	OCV at start of test, (Vdc)	Results	
Supplementary information: <ul style="list-style-type: none"> - No fire or explosion - No leakage - Leakage - Fire - Explosion - Bulge - Others (please explain) 			

7.3.1	TABLE: Incorrect installation (cells)		N/A
Model	OCV of reversed cell, (Vdc)	Results	

Supplementary information:

- No fire or explosion
- No leakage
- Leakage
- Fire
- Explosion
- Bulge
- Others (please explain)

7.3.2	TABLE: External short circuit				N/A
Model	Ambient (at 20°C ± 5°C or 55°C ± 5°C)	OCV at start of test, (Vdc)	Resistance of circuit, (Ω)	Maximum case temperature rise ΔT, (°C)	Results

Supplementary information:

- No fire or explosion
- No leakage
- Leakage
- Fire
- Explosion
- Bulge
- Others (please explain)

7.3.6	TABLE: Crush			N/A
Model	OCV at start of test, (Vdc)	OCV at removal of crushing force, (Vdc)	Results	
Supplementary information: <ul style="list-style-type: none"> - No fire or explosion - No leakage - Leakage - Fire - Explosion - Bulge - Others (please explain) 				

7.3.8	TABLE: Overcharge			N/A
Model	OCV prior to charging, (Vdc)	Maximum charge current, (A)	Time for charging, (hours)	Results
Supplementary information: <ul style="list-style-type: none"> - No fire or explosion - No leakage - Leakage - Fire - Explosion - Bulge - Others (please explain) 				

7.3.9	TABLE: Forced discharge (cells)				N/A
Model	OCV before application of reverse charge, (Vdc)	Measured reverse charge I_r , (A)	Time for reversed charge, (minutes)	Results	
Supplementary information: - No fire or explosion - No leakage - Leakage - Fire - Explosion - Bulge - Others (please explain)					

8.2.1	TABLE: Continuous charging at constant voltage (cells)				P
Model	Recommended charging voltage V_c , (Vdc)	Recommended charging current I_{rec} , (A)	OCV at start of test, (Vdc)	Results	
Cell #1	4.20	0.05	4.16	P	
Cell #2	4.20	0.05	4.17	P	
Cell #3	4.20	0.05	4.18	P	
Cell #4	4.20	0.05	4.18	P	
Cell #5	4.20	0.05	4.17	P	
Supplementary information: - No fire, no explosion, no leakage					

8.3.1	TABLE: External short circuit (cell)					P
Model	Ambient, (°C)	OCV at start of test, (Vdc)	Resistance of circuit, (Ω)	Maximum case temperature rise ΔT , (°C)	Results	
Samples charged at charging temperature upper limit (45°C)						
Cell 6#	23.0	4.16	0.08	103.9	P	
Cell 7#	23.0	4.16	0.09	100.9	P	
Cell 8#	23.0	4.16	0.09	103.6	P	
Cell 9#	23.0	4.16	0.09	104.9	P	
Cell 10#	23.0	4.16	0.09	107.7	P	
Samples charged at charging temperature lower limit (-5°C)						
Cell 11#	20.3	4.07	0.09	111.1	P	
Cell 12#	20.3	4.07	0.09	113.2	P	
Cell 13#	20.3	4.07	0.08	108.2	P	
Cell 14#	20.3	4.07	0.09	109.8	P	
Cell 15#	20.3	4.07	0.09	119.4	P	
Supplementary information:						
- No fire, no explosion						

8.3.2	TABLE: External short circuit (battery)					P
Model	Ambient, (°C)	OCV at start of test, (Vdc)	Resistance of circuit, (Ω)	Maximum case temperature rise ΔT , (°C)	Results	
Samples charged at charging temperature upper limit (45°C)						
Battery 1#	55.5	4.16	0.08	56.0	P	
Battery 2#	55.5	4.16	0.08	56.0	P	
Battery 3#	55.5	4.17	0.09	56.0	P	
Battery 4#	55.5	4.17	0.09	55.8	P	
Battery 5#	55.5	4.18	0.09	55.9	P	
Samples charged at charging temperature lower limit (-5°C)						
Battery 6#	55.1	4.07	0.09	55.6	P	
Battery 7#	55.1	4.06	0.08	55.5	P	
Battery 8#	55.1	4.08	0.09	55.6	P	
Battery 9#	55.1	4.09	0.08	55.4	P	
Battery 10#	55.1	4.09	0.08	55.5	P	
Supplementary information:						
- No fire, no explosion						

8.3.5	TABLE: Crush					P
Model	OCV at start of test, (Vdc)	OCV at removal of crushing force, (Vdc)	Width/diameter of cell before crush, (mm)	Required deformation for crush, (mm)	Results	
Samples charged at charging temperature upper limit (45°C)						
Cell 29#	4.16	4.16	--	--	P	
Cell 30#	4.17	4.17	--	--	P	
Cell 31#	4.16	4.16	--	--	P	
Cell 32#	4.16	4.16	--	--	P	
Cell 33#	4.16	4.16	--	--	P	
Note: A 13kN force applied at the wide side of prismatic cells. Supplementary information: - No fire, no explosion.						

8.3.6	TABLE: Over-charging of battery				P
Constant charging current (A).....:		0.5		—	
Supply voltage (Vdc).....:		5		—	
Model	OCV before charging, (Vdc)	Resistance of circuit, (mΩ)	Maximum outer casing temperature, (°C)	Results	
Battery 17#	3.32	--	27.0	P	
Battery 18#	3.31	--	28.0	P	
Battery 19#	3.33	--	29.1	P	
Battery 20#	3.30	--	28.0	P	
Battery 21#	3.30	--	28.0	P	
Supplementary information: - No fire, no explosion					

8.3.7	TABLE: Forced discharge (cells)				P
Model	OCV before application of reverse charge, (Vdc)	Measured Reverse charge I_r , (A)	Time for reversed charge, (minutes)	Results	
Cell 34#	3.52	0.25	90	P	
Cell 35#	3.50	0.25	90	P	
Cell 36#	3.50	0.25	90	P	
Cell 37#	3.51	0.25	90	P	
Cell 38#	3.50	0.25	90	P	
Supplementary information:					
- No fire, no explosion					

8.3.8 T-5	TABLE: External short circuit (cell)					P
Model	Ambient, (°C)	OCV at start of test, (Vdc)	Resistance of circuit, (Ω)	Maximum case temperature rise ΔT , (°C)	Results	
Cell 39#	55.4	4.12	0.08	117.4	P	
Cell 40#	55.4	4.11	0.09	112.0	P	
Cell 41#	55.4	4.09	0.09	115.0	P	
Cell 42#	55.4	4.10	0.08	118.2	P	
Cell 43#	55.4	4.12	0.09	121.6	P	
Cell 44#	55.2	4.09	0.09	115.5	P	
Cell 45#	55.2	4.10	0.09	113.1	P	
Cell 46#	55.2	4.08	0.08	111.6	P	
Cell 47#	55.2	4.10	0.08	117.7	P	
Cell 48#	55.2	4.09	0.09	119.6	P	
Supplementary information:						
The external short-circuit test of 10 pcs samples performed after the test of Altitude, Thermal cycling, Vibration and Shock in sequence.						
-No excessive temperature rise, no rupture, no explosion and no fire.						

8.3.9	TABLE: Forced internal short circuit (cells)					P
Model	Chamber ambient, (°C)	OCV at start of test, (Vdc)	Particle location ¹⁾	Maximum applied pressure, (N)	Voltage drop, (mV)	Results
Cell 49#	45	4.12	1	390	68	P
Cell 50#	45	4.14	1	400	23	P
Cell 51#	45	4.15	1	400	10	P
Cell 52#	45	4.15	2	400	12	P
Cell 53#	45	4.14	2	400	15	P
Cell 54#	10	4.06	1	400	9	P
Cell 55#	10	4.06	1	400	7	P
Cell 56#	10	4.06	1	400	8	P
Cell 57#	10	4.06	2	400	16	P
Cell 58#	10	4.07	2	400	9	P
<p>Supplementary information:</p> <p>¹⁾ Identify one of the following:</p> <p>1: Nickel particle inserted between positive and negative (active material) coated area.</p> <p>2: Nickel particle inserted between positive aluminium foil and negative active material coated area.</p> <p>- No fire</p>						

National Difference			
Consumer Goods	Requirement + Test	Result - Remark	Verdict

ATTACHMENT TO TEST REPORT IEC 62133 (Ed 2.0) SINGAPORE NATIONAL DIFFERENCES

Differences according to.....: Consumer Protection (Consumer Goods Safety Requirements) Regulations [CGSR] as detailed in Appendix F Additional Safety Requirements Imposed by SPRING Singapore as the Safety Authority

Attachment Form No.....: SG_ND_IEC62133B

Attachment Originator TÜV Rheinland (Shenzhen) Co., Ltd.

Master Attachment Date 2015-08

Portable power banks ¹	<p>1 Portable power banks shall comply with the requirements of the following safety standards:</p> <p>1.1 IEC 62133:2012 Secondary cells and batteries containing alkaline or non-acid electrolytes – Safety requirements for portable sealed secondary cells, and for batteries made from them, for use in portable applications; and</p> <p>1.2 IEC 60950-1:2005+A1:2009+A2:2013 Information technology equipment – Safety – Part 1: General requirements</p> <p>OR</p> <p>1.3 Any other industry standard specific to power banks</p> <p>2 Portable power banks shall be supplied with the following safety information:</p> <p>2.1 ‘Minimum Instructions for use’ as specified below</p> <p>2.2 Instructions on how to charge the portable power bank</p> <p>2.3 Information on the minimum and maximum operating temperatures of the portable power bank</p>		N/A
-----------------------------------	--	--	-----

National Difference			
Consumer Goods	Requirement + Test	Result - Remark	Verdict
	<p>Minimum Instructions² for Use for Portable Power Banks to be provided with portable power banks to the customer</p> <p>a) The power bank will generate heat when charging. Always charge in a well ventilated area. Do not charge under pillows, blankets or on flammable surfaces.</p> <p>b) Keep the power bank away from heat sources, direct sunlight, combustible gas, humidity, water or other liquids.</p> <p>c) Do not disassemble, open, microwave, incinerate, paint or insert foreign objects into the power bank.</p> <p>d) Do not subject the power bank to mechanical shock such as crushing, bending, puncturing or shredding. Avoid dropping or placing heavy object on the power bank.</p> <p>e) Do not short-circuit the power bank or store it in a receptacle where it may be short-circuited by other metallic or conductive objects.</p> <p>f) Do not operate the power bank if it has been wet or otherwise damaged, to prevent against electric shock, explosion and/or injury. Contact the dealer or authorized agent.</p> <p>g) Power bank usage by children should be supervised.</p> <p>h) Please read the operating instructions (including charging instructions and information on the minimum and maximum operating temperatures), supplied with this power bank.</p>		N/A

-- End of Report --

Product: Lithium-ion Polymer Battery

Type Designation: HCP502030W

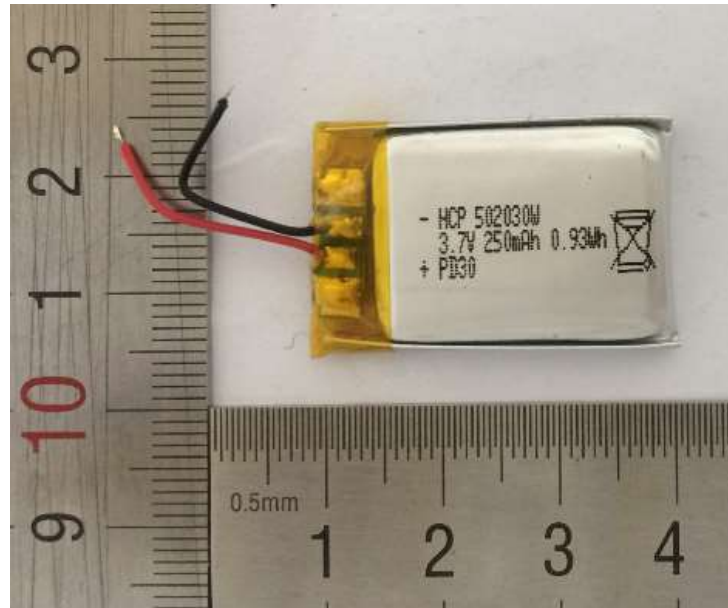

Figure 1 Front view of battery

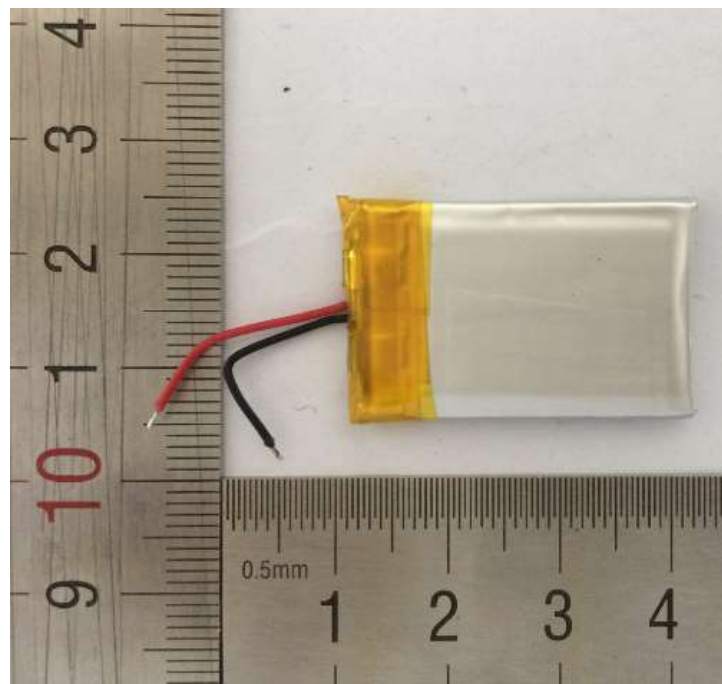

Figure 2 Back view of battery

Product: Lithium-ion Polymer Battery

Type Designation: HCP502030W

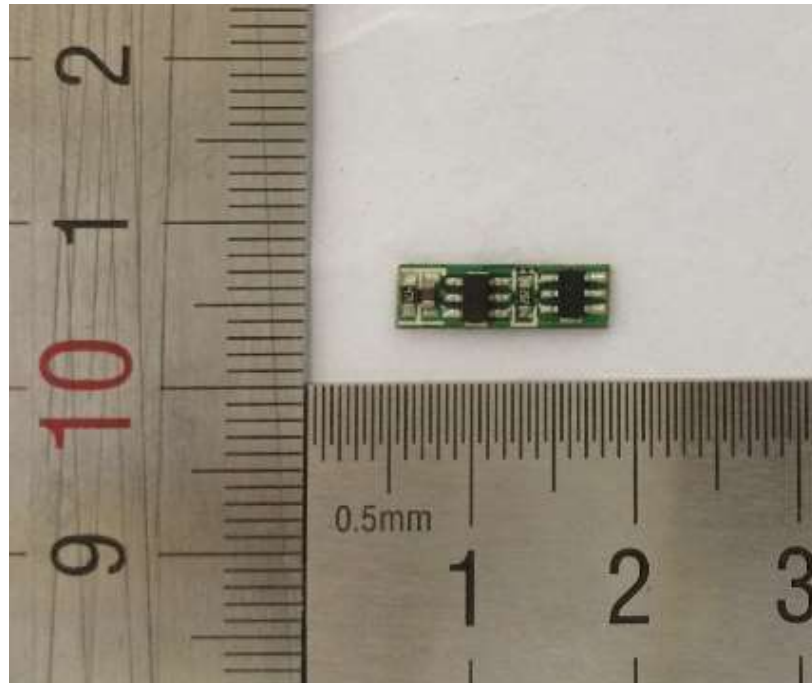

Figure 3 Component view of PCB

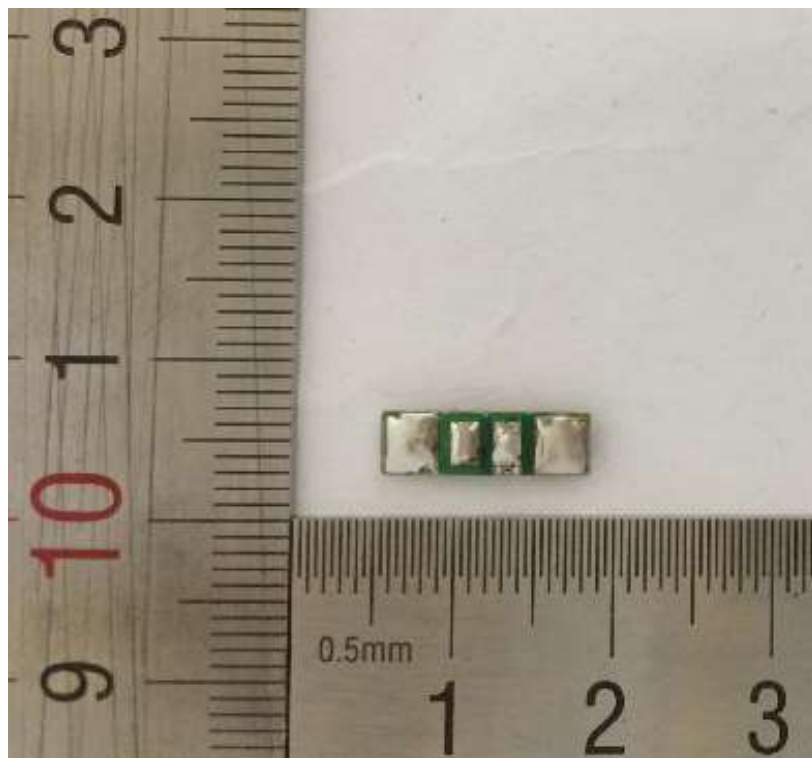

Figure 4 Trace view of PCB

Product: Lithium-ion Polymer Battery

Type Designation: HCP502030W

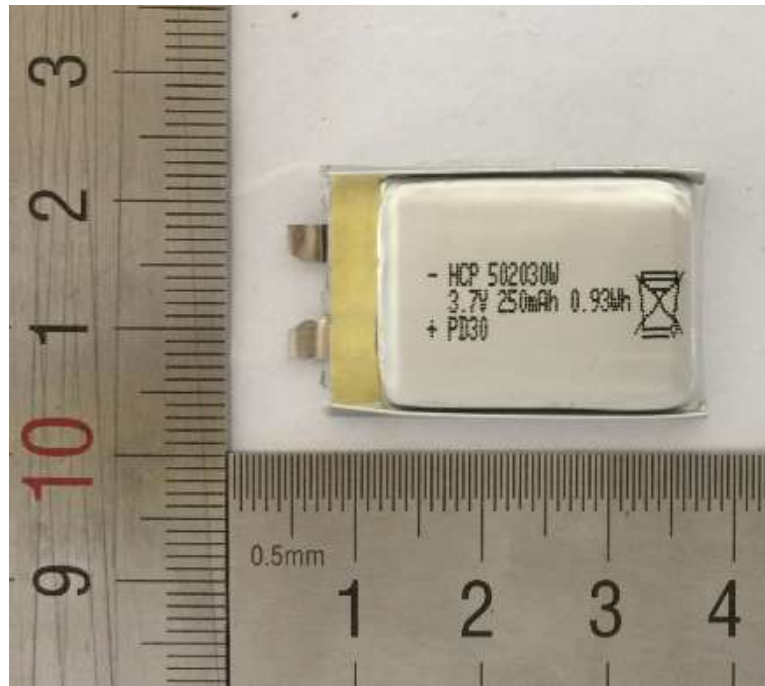

Figure 5 Front view of cell

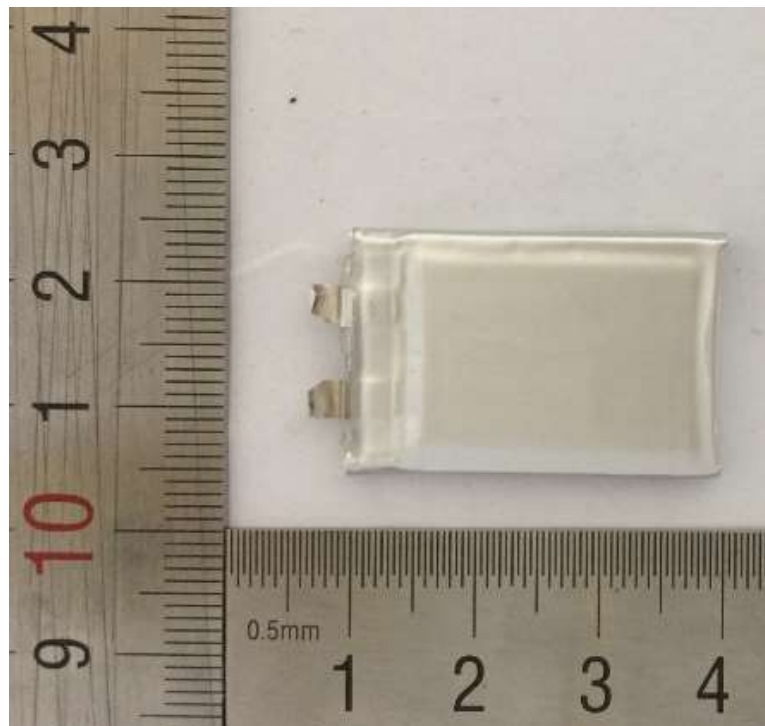

Figure 6 Back view of cell