



File Class:	LiFePO4 Batteries specifications	Version:	3.0
File Name:	Rechargeable Lithium ion Battery (Regular-rate)	Manufacturer :	Honcell Energy
Standard:	Compliant with RoHS, CE, FCC, UN38.3, REACH,KC,PSE IEC62133(TUV-CB), UL1642/2054 & GB31241-2014	Date:	2018-7-19

## Rechargeable LiFePO4 Battery

Customer's Model Number: HCF26650NFC

Honcell's Model Number: HCF26650NFC

Voltage / Capacity: 3.2V 3300mAh

Prepared By	Checked By	Approved By
 Date:	 Date:	 Date:

### Customer Approval

Comment: (Please return one copy with your approvals)

Signature:

Date:

**Shenzhen Honcell Energy Co., Ltd.**

612, Bldg. A, Weidonglong Industrial Zone,

Meilong Ave.194#, Longhua New District,

Shenzhen, 518109, China.

[t] +86-755-21005221

[f] +86-755-21000249

info@honcell.com

www.honcell.com

# CONTENT

1. Scope.....	4
2. Specification.....	4
3. Performance criteria.....	4
4. Production description .....	5
5. Model Nomenclature.....	5
6. Curves.....	6
7. Electrical characteristics.....	7
8. Protection Circuit Module (PCM) .....	8-9
9. Packing.....	10
10. Foreword.....	11-12

HONCELL+

## Modified List

Revision	Date	Mark	Modifications	Approved
ED-RE-0	2018-7-19		New Release	

HONCELL<sup>+</sup>

## 1. Scope

This specification describes the basic performance ,technical requirement ,testing method, warning and caution of the Rechargeable Lithium ion Batteries (Regular-rate) . The specification only applies to Honcell.

## 2. Specification

NO.	Item	Unit	Specifications	Remark
	Capacity	mAh	Typ. 3320mAh	0.2C Discharge
			Min. 3300mAh	
	Rated Voltage	V	3.2	Cell voltage between 3.0V to 3.4V before shipping
	Discharge Cut-off Voltage	V	2.0	
	Charge Cut-off Voltage	V	3.65	
	Standard Charging method		CC (constant current)	CC @0.2C charges to 3.65V, then @CV charges till charge current declines to $\leq 0.05C$
			CV (constant voltage)	
	Charge Current	A	3.3Max	
	Discharge Current	A	3.3Max	Peak Discharge Current 9.9A,1s Max
	Pack Weight	g	90.3	
	Impedance	m $\Omega$	160.0	Measure the internal resistance with AC=1KHz (since wave) after standard charge, 50% SOC.
	Operating Temperature	$^{\circ}C$	0 $^{\circ}C$ -45 $^{\circ}C$	Charge
			-20 $^{\circ}C$ -60 $^{\circ}C$	Discharge

## 3. Performance Criteria

### 3.1 Standard Test Condition

Test should be conducted with new batteries within one month after shipment from our factory and the cells shall not be cycled for more than five times before the test. Unless otherwise defined, test and measurement shall be done under the following condition:

Temperature : 20 $^{\circ}C$ ~30 $^{\circ}C$

Relative Humidity : 45%~85%RH

### 3.2 Measurement Apparatus

#### a) Dimension Measuring Instrument

The dimension measurement shall be implemented by instruments with equal or more precision scale of 0.01mm.

#### b) Voltmeter

Standard class specified in the national standard or more sensitive class having inner impedance not less than 10K $\Omega$ /V.

#### c) Ammeter

Standard class specified in the national standard or more sensitive class. Total external resistance including ammeter and wire is less than 0.01 $\Omega$ .

d) Impedance shall be measured by a sinusoidal alternating current method (AC 1kHz LCR meter). Resistance is not a constant value according to the change of temperature and charge state of saturation, and related to lead length and capacity

e) All test equipments and measuring instruments are subject to passing inspection institutes.

f) Battery test system at the current accuracy should be within  $\pm 0.1\%$ , constant within  $\pm 0.5\%$  accuracy, timing accuracy within  $\pm 0.1\%$ .

g) Temperature measurement accuracy of instruments should not be less than  $\pm 0.5^{\circ}C$ .

## 4. Production Description

### 4.1 Battery Pack Mechanical Drawing (not in scale)

\*\*\*All the below materials shall be environmental friendly and RoHS compliant\*\*\* (unit: mm)

NO.	Item Name	Model	Qty.
01	Cell	HCF26650	1
02	PCM	S-8261DAT	1
03	Red Wire (P+)	UL1571-AWG#16	1
04	Black Wire (P-)	UL1571-AWG#16	1
05	Yellow Wire (P+)	UL1571-AWG#16	1
06	Connector	JST-VHR-0300	1
07	Bule PVC	***	1
08	Printing	***	***

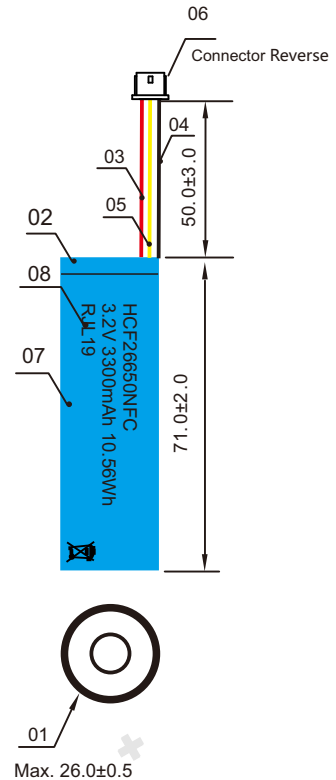

### 4.2 Bare Cell Mechanical Drawing (Not in Scale)

Dimensions [mm]

NO.	Item Name	Model
	Diameter[mm]	Max. 26.35
	Length[mm]	Max. 65.3
	Impedance Initial [mΩ]	<60 @ 1kHz at 3.65V
	Weight Approx.(g)	90.0

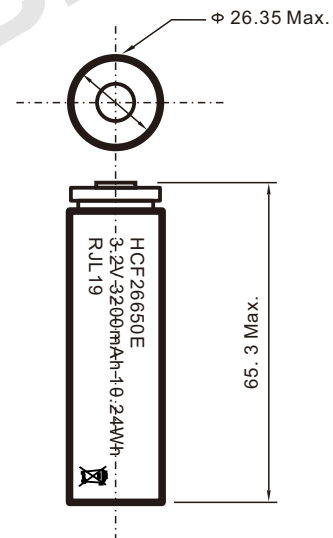

## 5. Model Nomenclature

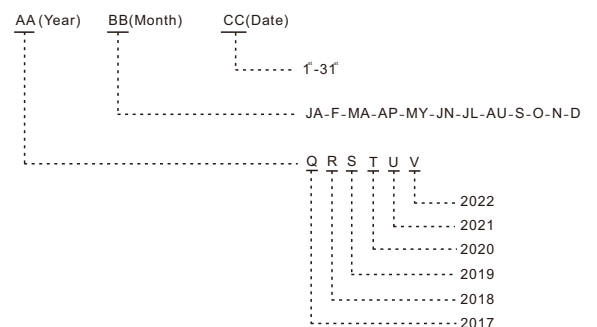
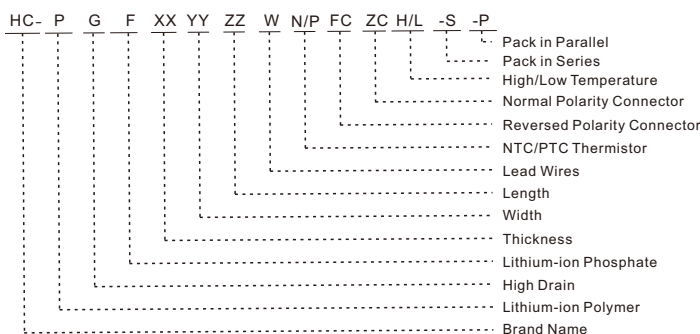

## 6. Curves

Charge & Discharge (25°C)

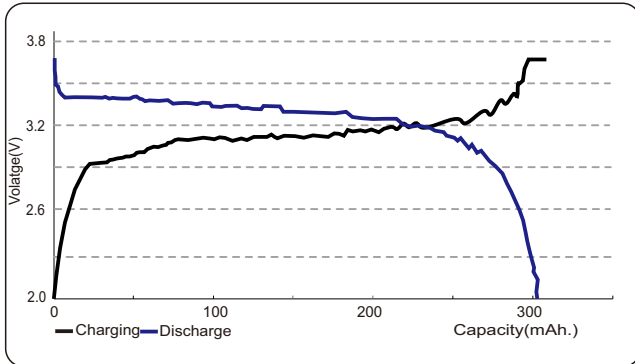

Cycle Life

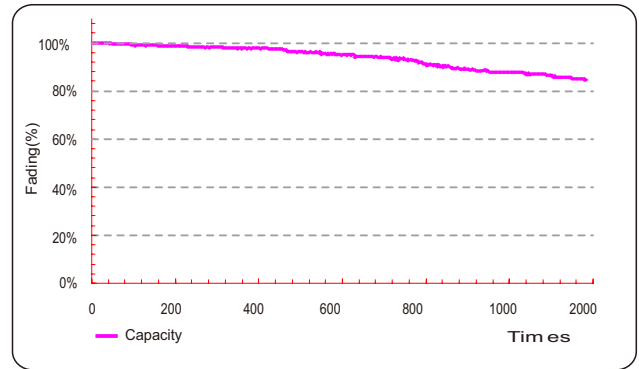

Discharge Characteristics (Temperature)

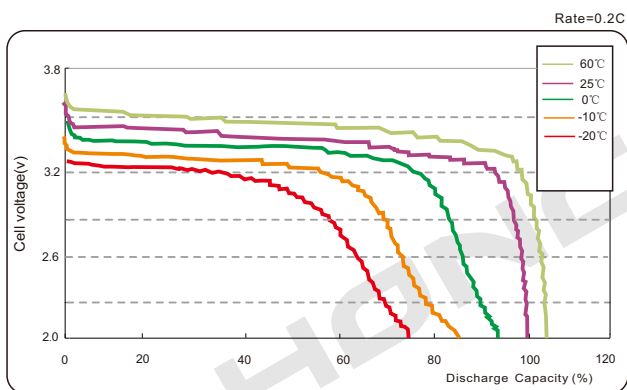

Discharge Characteristics (Rate)

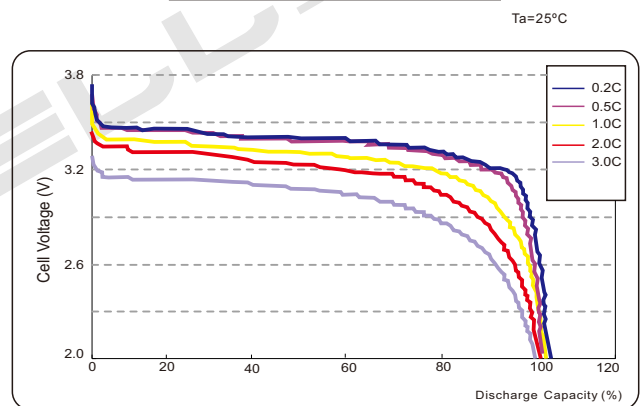

## 7. Electrical Characteristics

Items	Test Method and Condition			Criteria
Standard Charge	Charging the cell initially with constant current at 1C and then with constant voltage at 3.65V till charge current declines to 0.05C.			N.A
Rated Cap 0.2C	Capacity measured with discharge current of 0.2C with 2.0V cut-off voltage after the standard charge.			≥3300mAh
Rated Cap 0.5C	Capacity measured with discharge current of 0.5C with 2.0V cut-off voltage after the standard charge.			≥3300mAh
Rated Cap 1.0C	Capacity measured with discharge current of 1.0C with 2.0V cut-off voltage after the standard charge.			≥3280mAh
Rated Cap 2.0C	Capacity measured with discharge current of 2.0C with 2.0V cut-off voltage after the standard charge.			≥3260mAh
Rated Cap 3.0C	Capacity measured with discharge current of 3.0C with 2.0V cut-off voltage after the standard charge.			≥3240mAh
Cycle Life	Test condition: Temperature: 23±5°C Charge: 0.5C CC to 3.65V, and CV to 0.05C cut off Discharge: 0.5C discharge to 2.0V 70% or more of 1 <sup>st</sup> cycle capacity at 0.5C discharge of operation			≥2000 times
Storage performance	Battery cell stored at 25°C with 50% SOC			
		1Month	3Month	6Month
	Cap Retention	90%	85%	80%
	Cap Recovery	95%	90%	85%
Initial Impedance	Internal resistance measured at AC 1KHz after 50% charge			≥12mohm
Cell Voltage	As of shipment			3.0V ~ 3.4V

## 8. Protection Circuit Module (PCM)

### 8.1 PCM Top Layers

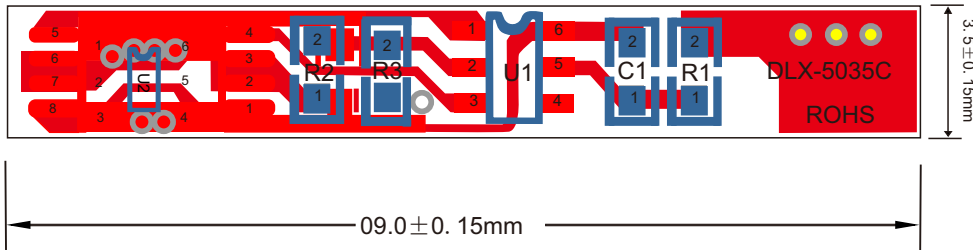

### 11.2 PCM Bottom Layer and Size

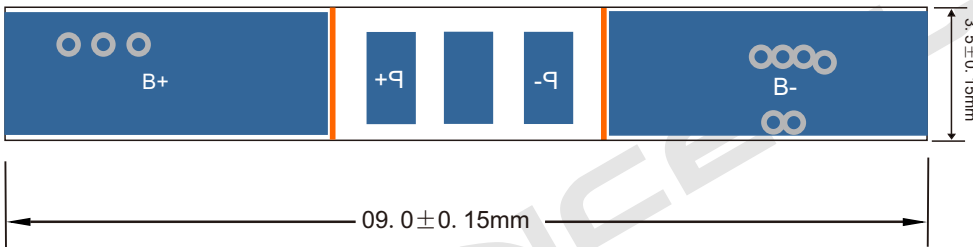

### 11.3 BOM of PCM

No.	Location	Item	Part Name	Package	Qty.	Supplier/ Remark
1	U1	Protection IC	S-8261DAI-M6T1U	SOT-23-6	1	SEIKO
2	U2,U3	MOSFET	8205A	TSSOP-8	2	MT
3	R1	Resistor	SMD 470Ω±5%	0603	1	YAGEO
4	R2	Resistor	SMD 2KΩ±5%	0603	1	YAGEO
5	C1	Capacitor	SMD 0.1μF±20%	0603	1	YAGEO
6	R3	NTC	SMD 10KΩ±1% B=3435K	0603	1	YAGEO
7	PCB	PCB	(09.0*3.5*0.6)±0.15mm LxWxT		1	ASSUN/FR4 RoHS



## 9. Protection Circuit Module (PCM)

### 9.1 PCM Application Schematic

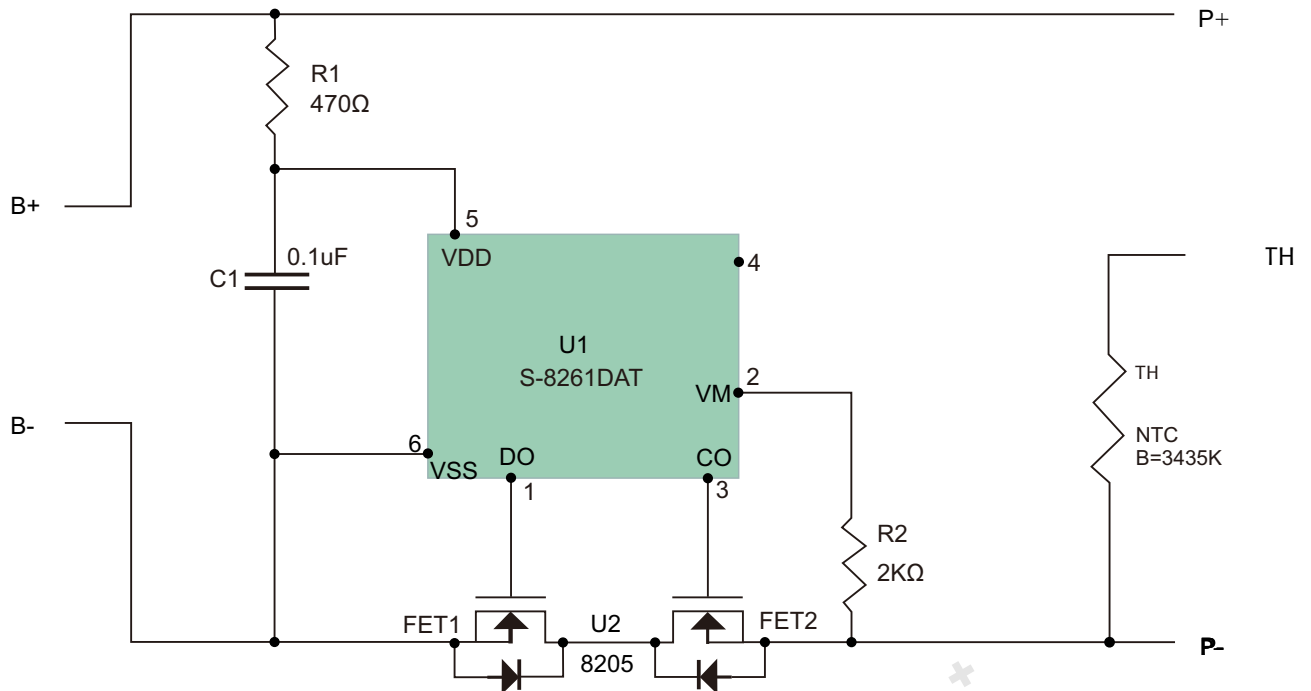

### 9.2 PCM Parameter

Item	Content	Criteria
Over Charge Protection	Over Charge Detection Voltage	3.65±0.025V
	Over Charge Detection Delay Time	0.7s to 1.3s
	Over Charge Release Voltage	3.450±0.05V
Over Discharge Protection	Over Discharge Detection Voltage	2.0±0.05V
	Over Discharge Detection Delay Time	179.2ms to 332.8ms
	Over Discharge Release Voltage	2.1±0.05V
Over Current Protection	Charge Over Current Detection Delay Time	11.2ms to 20.8ms
	Over Current Detection Current	0.5~12.0A
	Discharge Over Current Detection Delay Time	11.2ms to 20.8ms
	Over Discharge Current Release Condition	Cut load
Short Protection	Detection Delay Time	364μs Max.
	Release Condition	Cut short circuit
	Load Short Circuit Detection Voltage	0.6V±0.1V
Interior Resistance	Main Loop Electrify Resistance	VC=3.65V,RDS≤60mΩ
Current Consumption	Current Consume in Normal Operation	1.5μA Type 4.0μA Max

## 10. Packing

10.1 One medium box contains 8 Batteries.

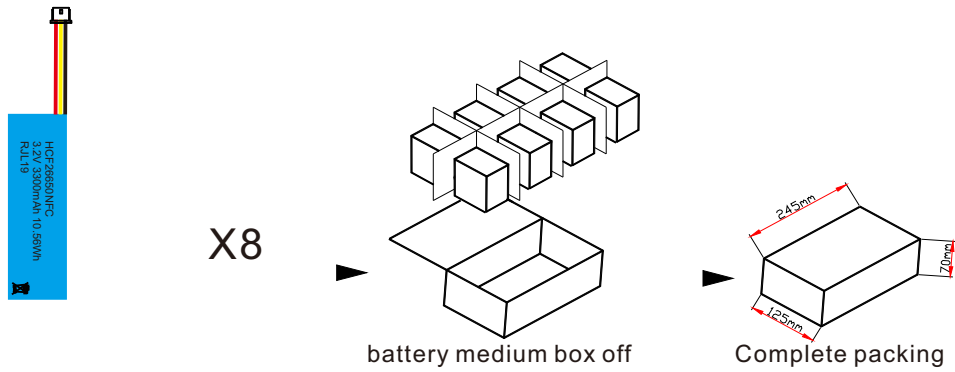

10.2 Affix fire label to the medium box.

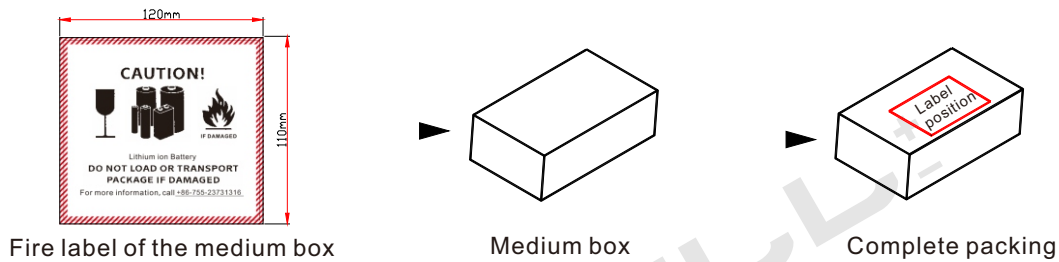

10.3 Put medium box in the carton.

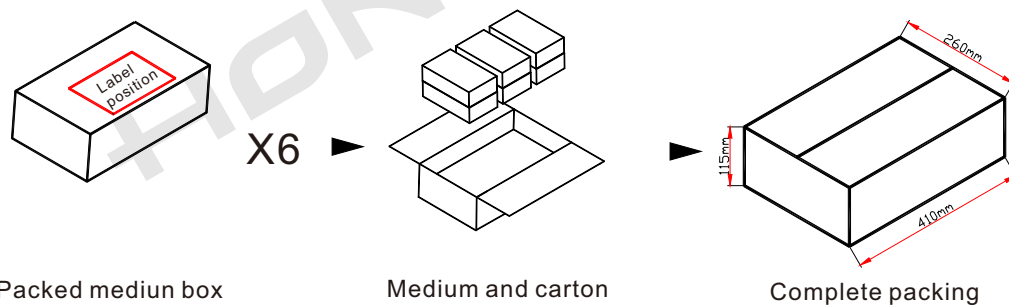

10.4 Affix shipping mark and fire label to the right of the packaged carton.

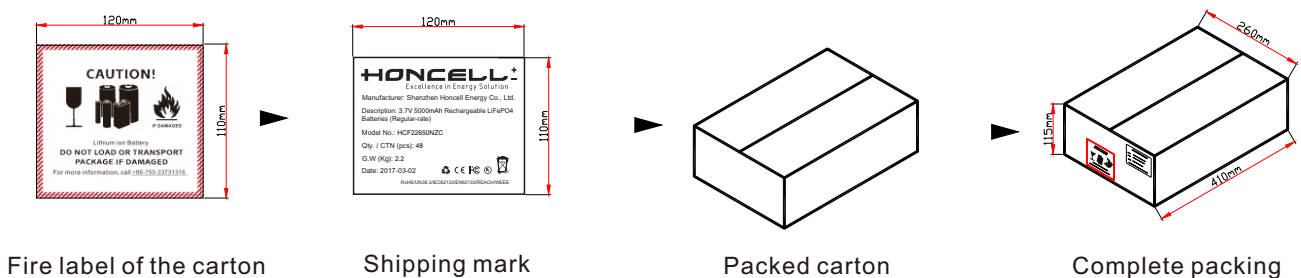

## Handling Precautions and Guideline For Li-ion Rechargeable Batteries

### 11. Foreword

This document of 'Handling Precautions and Guideline For Rechargeable Lithium ion Batteries (Regular-rate) shall be applied to the cells manufactured by Hocell.

#### Statement(1):

Customers are requested to contact Hocell. in advance, if and when the customer needs other applications or operating conditions than those described in this document. Additional experimentation may be required to verify performance and safety under such conditions.

#### Statement(2):

Hocell will take no responsibility for any accident when the cell is used under other conditions than those described in this Document.

#### Statement(3):

Hocell will inform, in a written form, customers of improvement regarding proper usage and handling of cells, if it is deemed necessary.

### 11.1 Appendix

#### 11.1.1 Standard Charge/Discharge

a) Standard charge : Test procedure and its criteria are referred as follows :

0.2 C=Charging shall consist of charging at a 0.2 C constant current rate until the cell reaches 3.65V The cell shall then be charged at constant voltage of 3.65v when the charging current has tapered to 0.02 C.

Charge time : Approx 5-6h,

b) Standard Discharge

0.2C=Cells shall be discharged at a constant current of 0.2C to 2 volts @25°C±5°C.

d) If no otherwise specified, the rest time between Charge and Discharge amount to 30min.

#### 11.1.2 Appearance

There shall be no such defect as flaw, crack, rust, leakage, which may adversely affect commercial value of battery.

### 11.2 Warning

a)Prohibition short circuit

b)Notice for Designing Battery Pack

Pack toughness

Battery pack should have sufficient strength and the Li-ion cell inside should be protected from mechanical shocks.

#### Cell fixing

The Li-ion cell should be fixed to the battery pack by its large surface area. No cell movement in the battery pack should be allowed.

#### Tab connection

Spot welding is recommended for Li-ion tab connection method. Battery pack should be designed that shear force are not applied to the Li-ion tabs.

#### Prohibition of disassembly

a ) Never disassemble the cells

The disassembling may generate internal short circuit in the cell, which may cause gassing, firing, explosion, or other problems.

b) Electrolyte is harmful

Li-ion battery should not have liquid from electrolyte flowing, but in case the electrolyte come into contact with the skin, or eyes, physicians shall slush the electrolyte immediately with fresh water and medical advice is to be sought.

Prohibition of dumping of cells into fire

Never incinerate nor dispose the cells in fire. These may cause explosion of the cells, which is very dangerous and is prohibition.

Battery cells replacement

The battery replacement shall be done only by either cells supplier or device supplier and never be done by the user.

Prohibition of use of damaged cells.

The cells might be damaged during shipping by shock. If any abnormal features of the cells are found such as damages in a plastic envelop of the cell, deformation of the cell package, smelling of an electrolyte ,an electrolyte leakage and others, the cells shall never be used any more. The cells with a smell of the electrolyte or a leakage shall be placed away from fire to avoid firing or explosion.

Period of Warranty

The period of warranty is half a year from the date of shipment. Mottcell guarantees to give a replacement in case of cells with defects proven due to manufacturing process instead of the customer abuse and misuse.

Storing the Batteries

The batteries should be stored at room temperature, charged to about 30% to 50% of capacity. We recommend that batteries be charged about once per half a year to or event over discharge.

Other The Chemical Reaction

Because batteries utilize a chemical reaction, battery performance over time even if stored for a long period of time without being used. In addition, if the various usage conditions such as charge, ambient temperature, etc. are not maintained within the specified ranges the life expectancy of the battery may be shortened or the device in which the battery is used may be damaged by electrolyte leakage. if the batteries cannot maintain a charge for long periods of time, even when they are charged correctly, this may indicate it is time to change the battery.

Note:

Any other items which are not covered in this speciation shall be agreed by both parties.

Company Name: \_\_\_\_\_ Signature: \_\_\_\_\_ Date: \_\_\_\_\_